

SPINDLE PADS FOR PSA & H&L DISCS

These spindle pads are designed to hold small diameter PSA or H&L discs. The pad diameters are slightly undersized by design to protect the edge. Shanks are threaded and can be removed leaving a 1/4-20 female arbor.

ABRAS DIAMETER	PAD DIAMETER	SHANK	PSA PADS		H & L PADS	
			EDP #	PAD #	EDP #	PAD #
3/4"	0.75"	1/4"	151039	405-AM-4S		
1"	0.91"	1/4"	151040	413-AM-4S	151057	413-HM-4S
1 1/4-1 1/2"	1.17"	1/4"	151042	406-AM-4S		
2"	1.85"	1/4"	151044	407-AM-4S	151058	407-HM-4S
3"	2.87"	1/4"	151048	409-AM-4S	151059	409-HM-4S

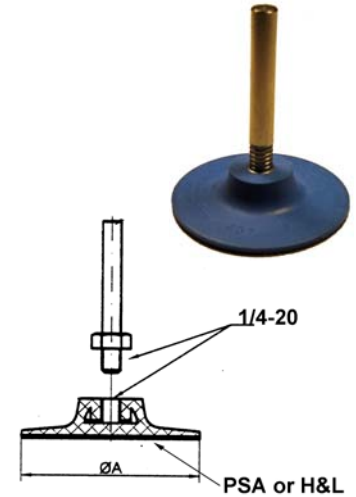

PADS FOR H&L DISCS

KOLTEC USA's pads for H&L discs are typically used in finishing and polishing applications with H&L abrasive or diamond discs. Pads with water feed holes are commonly used in the polishing of marble, granite, and other ceramic material in a wet mode. They can be used in both wet and dry applications.

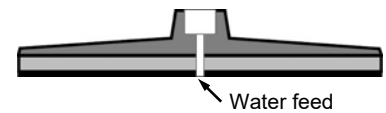

Spindle pads with 1/4" shank



Pads with foam interlayer and a water feed hole. Can be used wet or dry.



Pads without foam layer for firmer action. Available with or without water hole.

EDP #	PAD #	DIAM	ARBOR	SURFACE	FOAM	WATER Ø	RPM
151052	SP2-3-H	2"	1/4" Shank	H&L	3/4"	No	6,000
151053	SP3-3-H	3"	1/4" Shank	H&L	3/4"	No	6,000
151405	355-1MH3126W-5	3"	5/8-11	H&L	1/2"	Yes	20,190
151406	355-1MH3125-3	3"	3/8-24	H&L	1/2"	No	20,190
151409	399-1MH3126W-5	4"	5/8-11	H&L	1/2"	Yes	15,000
151606	399-1LHW-5	4"	5/8-11	H&L	None	Yes	15,000
151601	375-1LH-5	4 1/2"	5/8-11	H&L	None	No	13,000
151414	376-1MH3126W-5	5"	5/8-11	H&L	1/2"	Yes	12,000
151607	376-1LHW-5	5"	5/8-11	H&L	None	Yes	12,000
151605	376-1LH-5	5"	5/8-11	H&L	None	No	12,000
151611	376-1LH-M14	5"	M14	H&L	None	No	12,000
151429	314-1MH3126W-5	6"	5/8-11	H&L	1/2"	Yes	10,000
151602	314-1LH-5	6"	5/8-11	H&L	None	No	10,000
151430	392-1MH3126W-5	7"	5/8-11	H&L	1/2"	Yes	8,500
151617	392-1LH-5	7"	5/8-11	H&L	None	No	8,500
151433	337-1MH3126W-5	8"	5/8-11	H&L	1/2"	Yes	7,570
151434	337-1MH3426-5 (firm)	8"	5/8-11	H&L	3/8"	No	7,570